

***M131.M1.5.333***  
***5G/WIFI/GNSS 5 IN 1 Antenna***  
***test report***

*Version: V 1.1*

*Released Date: 2020/09/07*

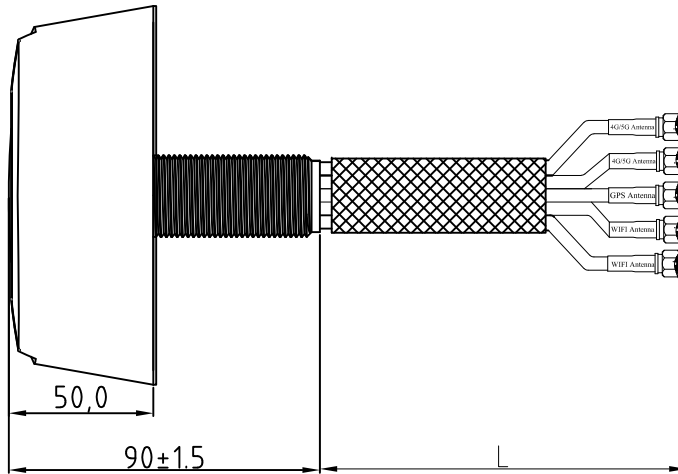
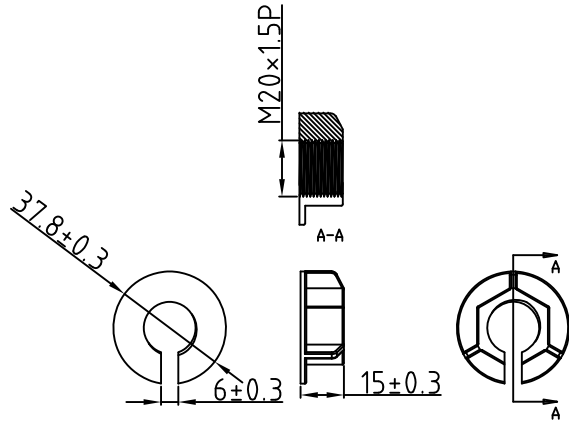
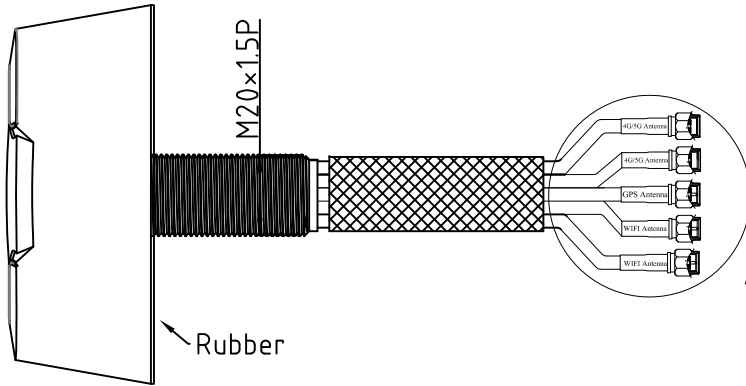
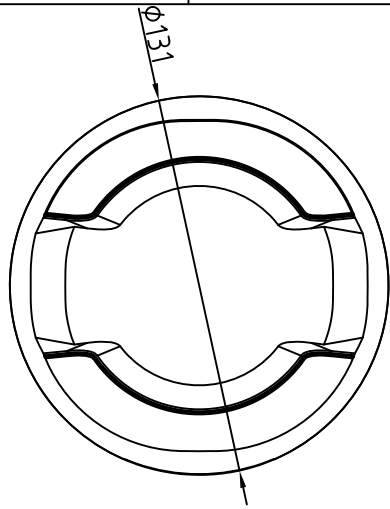

Electrical Properties	
Frequency Range	2* 600~6000MHZ
	2* 2.4~2.5GHZ
	5.15~7.125GHZ
	1* 1575.42~1602MHZ
Impedance	50 Ω
V.S.W.R.	5G ≤3.0
	WIFI ≤2.0
	GPS ≤2.0
Radiation	Omni
Gain	5G:6±1DBi
	WIFI:6±1DBi
	GPS:28±1DBi
Polarization	Vertical
Mechanical Properties	
Whip	PC+ABS
Standard Connector	SMA
Waterprooflevel	IP68
Operating Temp	-φ40°~ +85°

BOM

NO	Name	Material	Finish	QTY
1	Top	ABS+PC	BLACK	1
2	Bottom	ABS+PC	BLACK	1
3	LMR100 Coaxial cable	PE	BLACK	5
4	SMA Male	Brass	GOLD	5
5	Antenna			5
6	Screw installation	ABS+PC	BLACK	1
7	NUT	PA66	BLACK	1
8	Shrink tube	PE		5
9				

THIRD ANGLE PROJECTION

Tolerance  
 .X ±0.1  
 .XX ±0.05  
 .x ±1°

DRAWN BY	li	MATERIAL:		PART NO:	M131.M1.5.331
CHECKED BY		FINISH:	BLACK	TITLE:	5G+WIFI+GPS 5 in 1
APPROVED BY	King	UNIT:	mm		
DATE:	20.9.7	SCALE:	1/1		



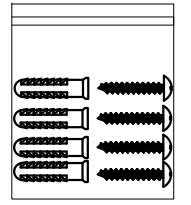
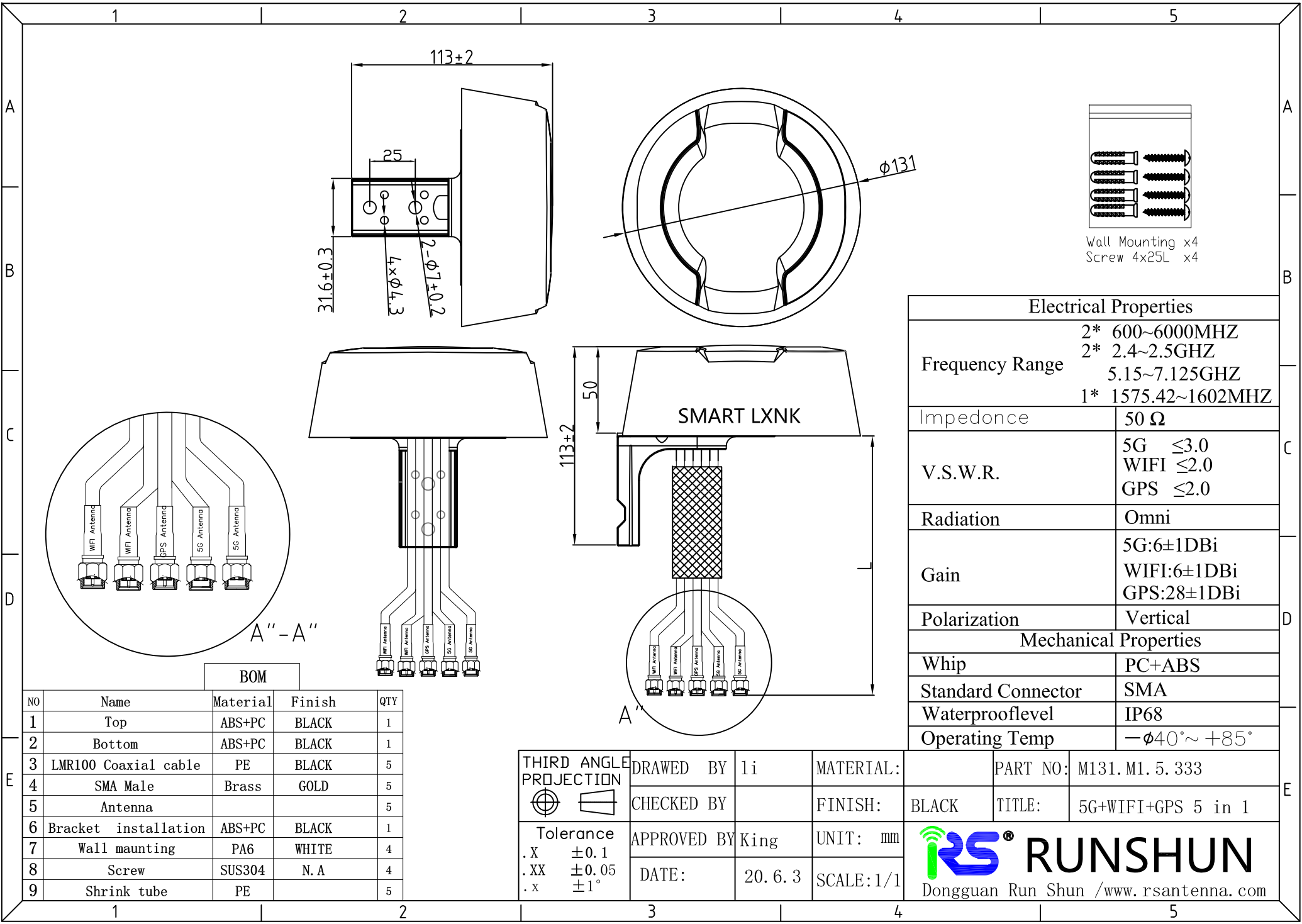

Wall Mounting x4  
Screw 4x25L x4

Electrical Properties	
Frequency Range	2* 600~6000MHZ
	2* 2.4~2.5GHZ
	5.15~7.125GHZ
	1* 1575.42~1602MHZ
Impedance	50 Ω
V.S.W.R.	5G ≤3.0
	WIFI ≤2.0
	GPS ≤2.0
Radiation	Omni
Gain	5G:6±1DBi
	WIFI:6±1DBi
	GPS:28±1DBi
Polarization	Vertical
Mechanical Properties	
Whip	PC+ABS
Standard Connector	SMA
Waterprooflevel	IP68
Operating Temp	-φ40°~ +85°

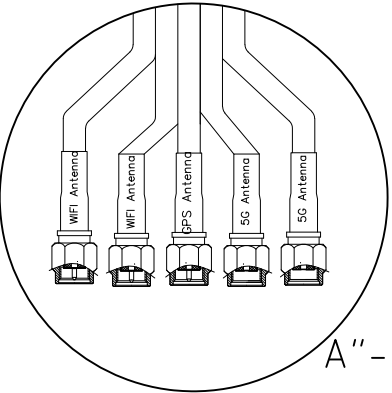

BOM

NO	Name	Material	Finish	QTY
1	Top	ABS+PC	BLACK	1
2	Bottom	ABS+PC	BLACK	1
3	LMR100 Coaxial cable	PE	BLACK	5
4	SMA Male	Brass	GOLD	5
5	Antenna			5
6	Bracket installation	ABS+PC	BLACK	1
7	Wall maunting	PA6	WHITE	4
8	Screw	SUS304	N. A	4
9	Shrink tube	PE		5

THIRD ANGLE PROJECTION

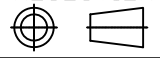

Tolerance	.X ±0.1
	.XX ±0.05
	.x ±1°

DRAWN BY	li	MATERIAL:		PART NO:	M131.M1.5.333
CHECKED BY		FINISH:	BLACK	TITLE:	5G+WIFI+GPS 5 in 1
APPROVED BY	King	UNIT:	mm	 Dongguan Run Shun /www.rsantenna.com	
DATE:	20.6.3	SCALE:	1/1		

## *Contents*

- Revised History
- Specification
- Antenna Placement & Solution
- Return Loss & Isolation Results
- Test Setup
- Efficiency & PeakGain & Gain Table
- 2D Radiation Pattern Results

## Revision History

Released Date	Version	Record
2020/08/25	1.0	Antenna test report
2020/09/07	1.1	Increase Antenna Frequency to 6GHz

# Specification

## Requirements of Antenna Design

RF Function	Number of ANT	Frequency Band	Remark
5G NR FR1	2	698~960/1710~2690/3300~4200/5150~5850MHz	
WIFI	2	2400~2500/5150~5850MHz	
GNSS	1	1575.42MHz/1602MHz	

## Requirements of Measurement

Test Item	Specification	Remark
Return Loss	<-6dB@5G NR FR1 <-6dB@WiFi <-10dB@GNSS	
Peak gain (without cable loss)	5G : 2dBi@698~960MHz; 4dBi@1710~2690MHz; 5dBi@3300~3800MHz; 6dBi@5150~5850MHz WiFi: 2dBi@2400~2500MHz; 6dBi@5150~5850MHz	
Efficiency (without cable loss)	5G : 50~80%@698~960; 50~80%@1710~2690; 45~70%@3300~3800; 45~70%@5150~5850 WiFi: 50~60%@2400~2500MHz; 50~80%@5150~5850MHz	

# Specification\_GNSS

## Passive

Test Item	Specification	Remark
Frequency	1570~1605	
Polarization	RHCP	
Gain	5dBic (Zenith)	
V. S. W. R	<1.5	
Axial Ratio	3dB (max)	

## Active

Test Item	Specification	Remark
Gain	$28 \pm 2$ dB	
Noise Figure	<2.5	
Filter Insertion Loss	<3dB	
Supply Voltage	2.2~5V DC	
Current Consumption	5~15mA	

# Return Loss\_5G

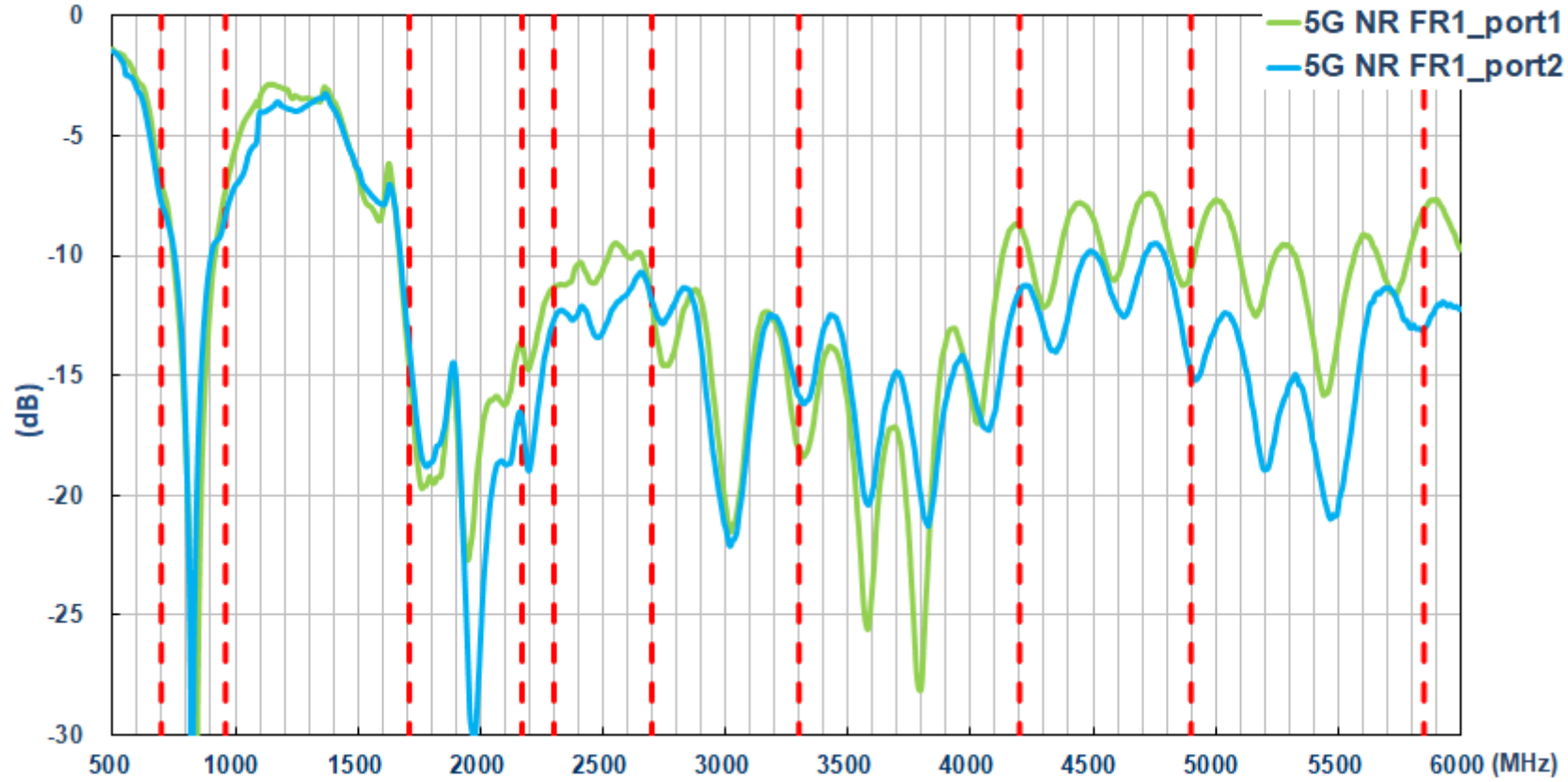



# Return Loss\_WiFi

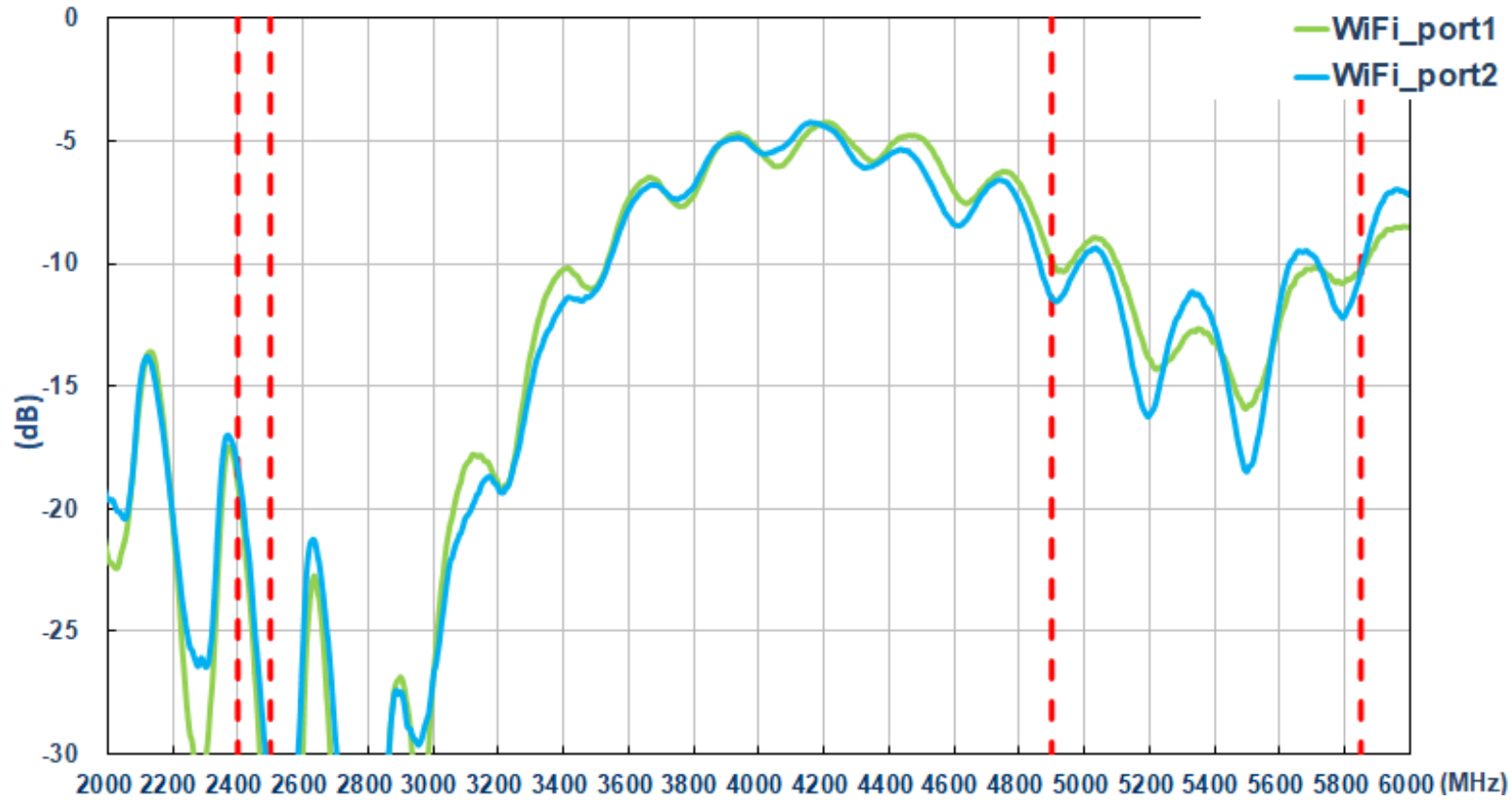

# Isolation\_5G

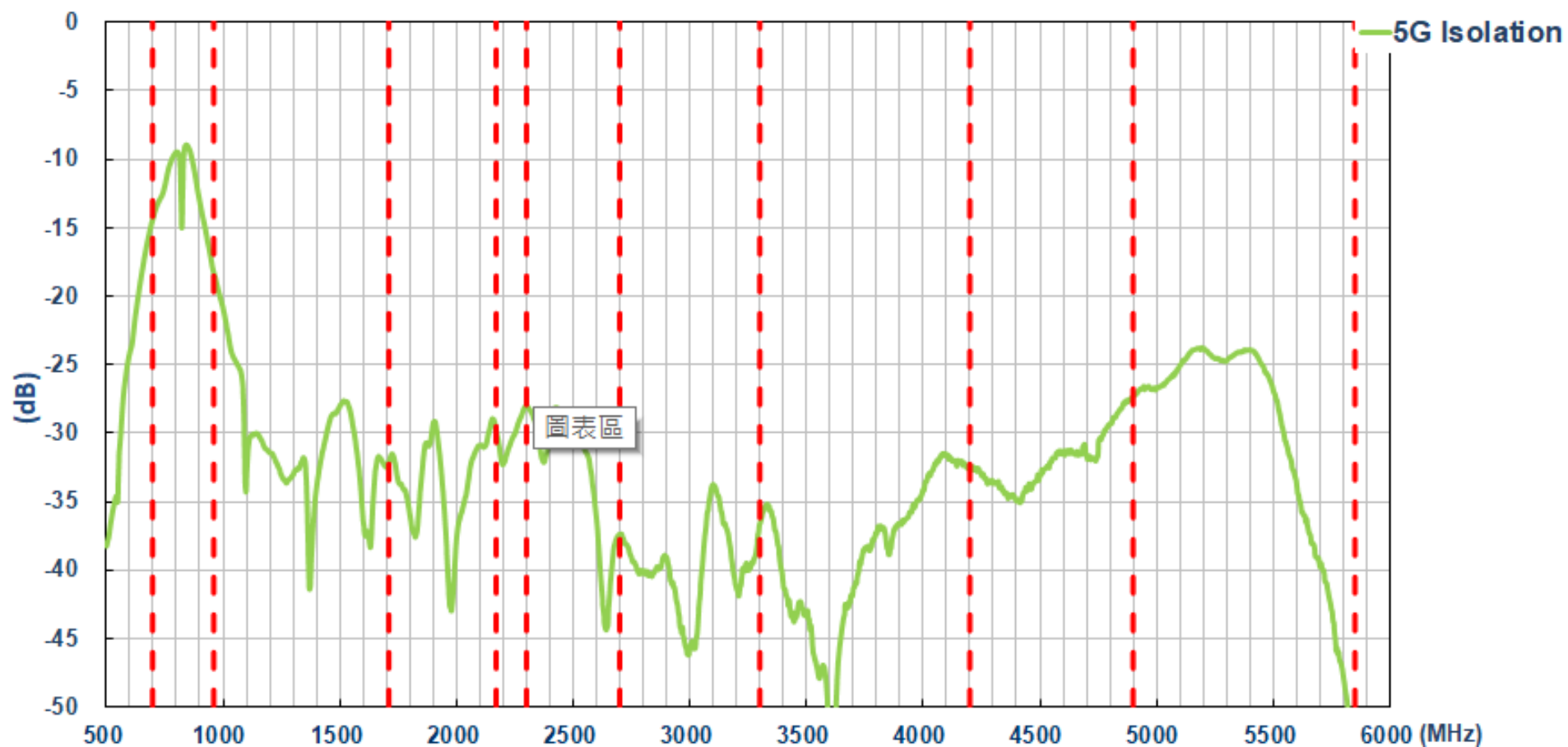

# Isolation\_WiFi

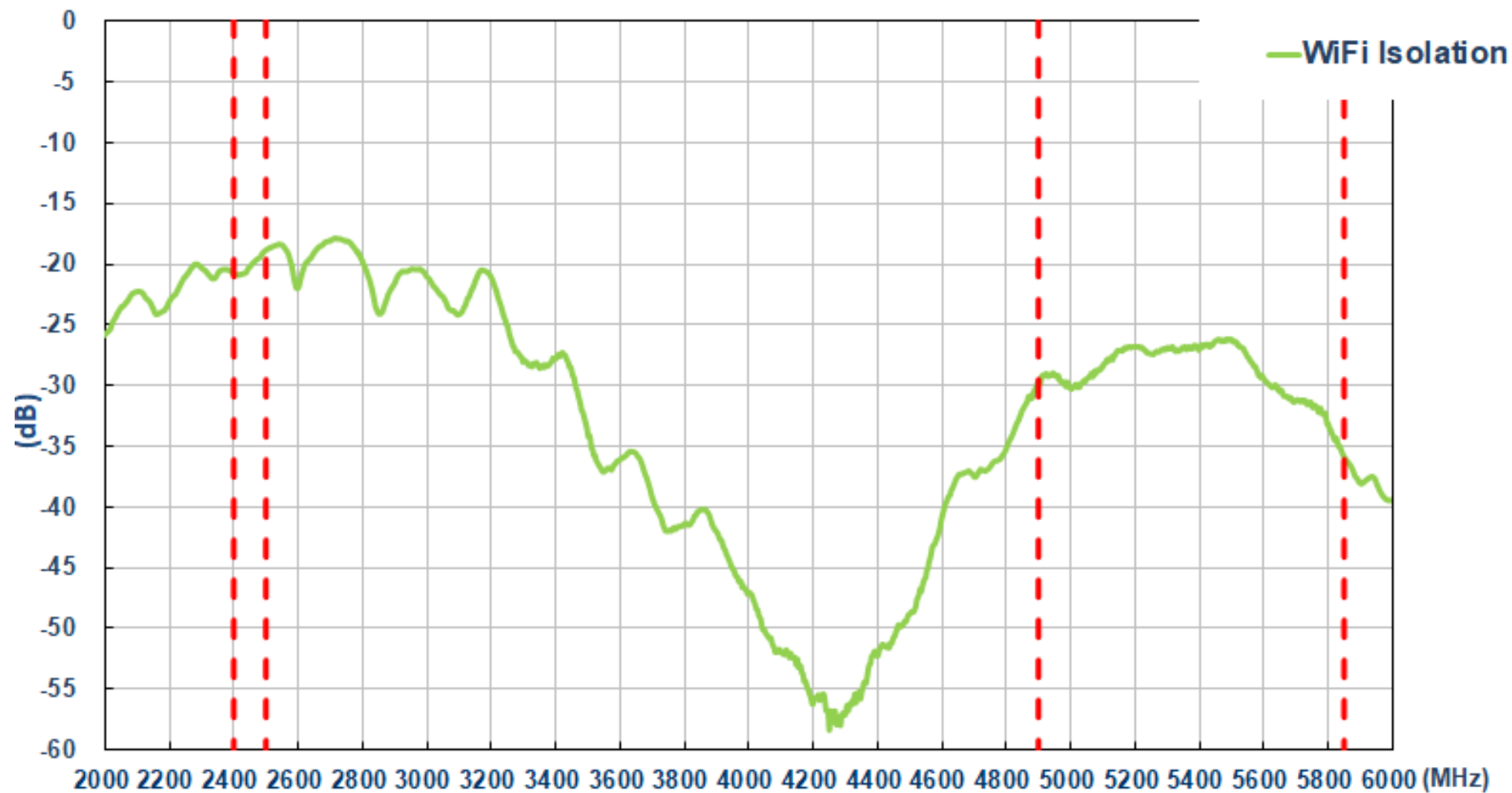

## Test Setup

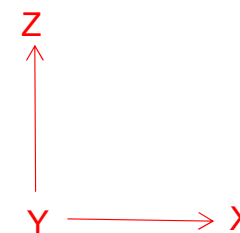
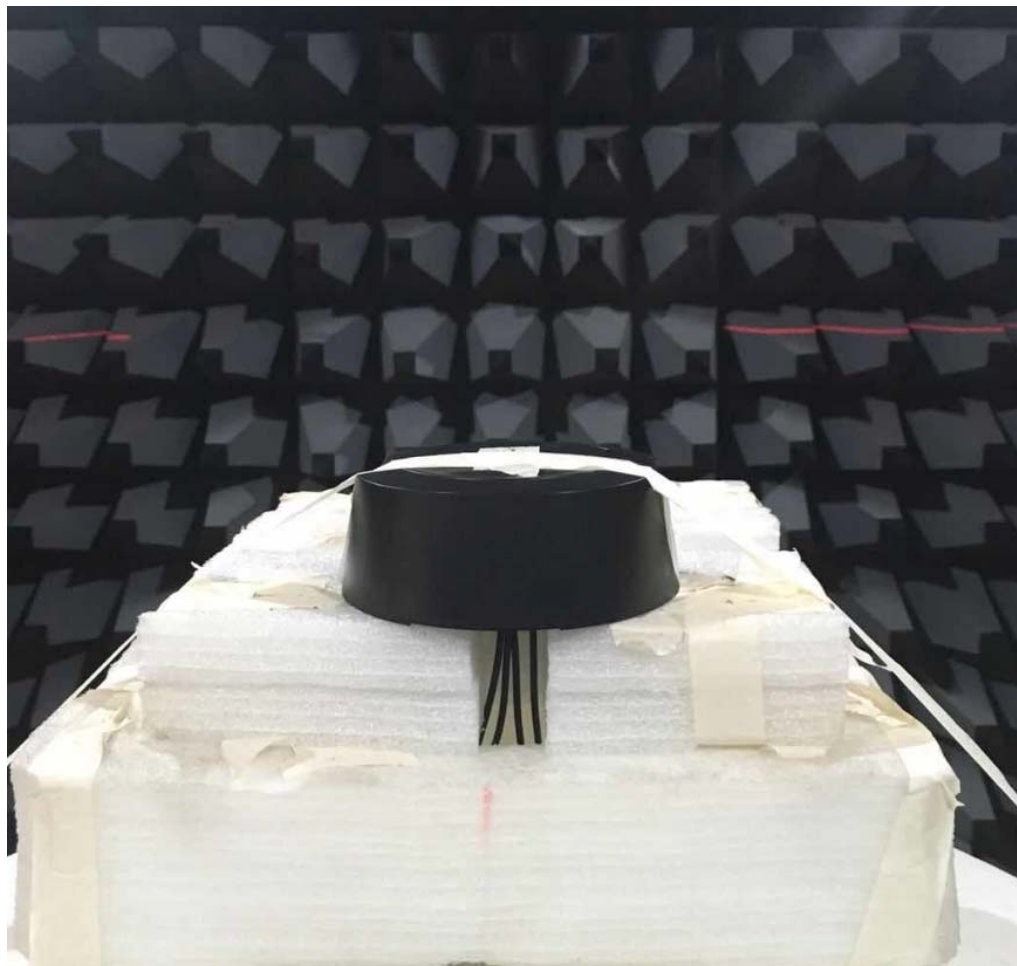

# Efficiency\_5G NR FR1

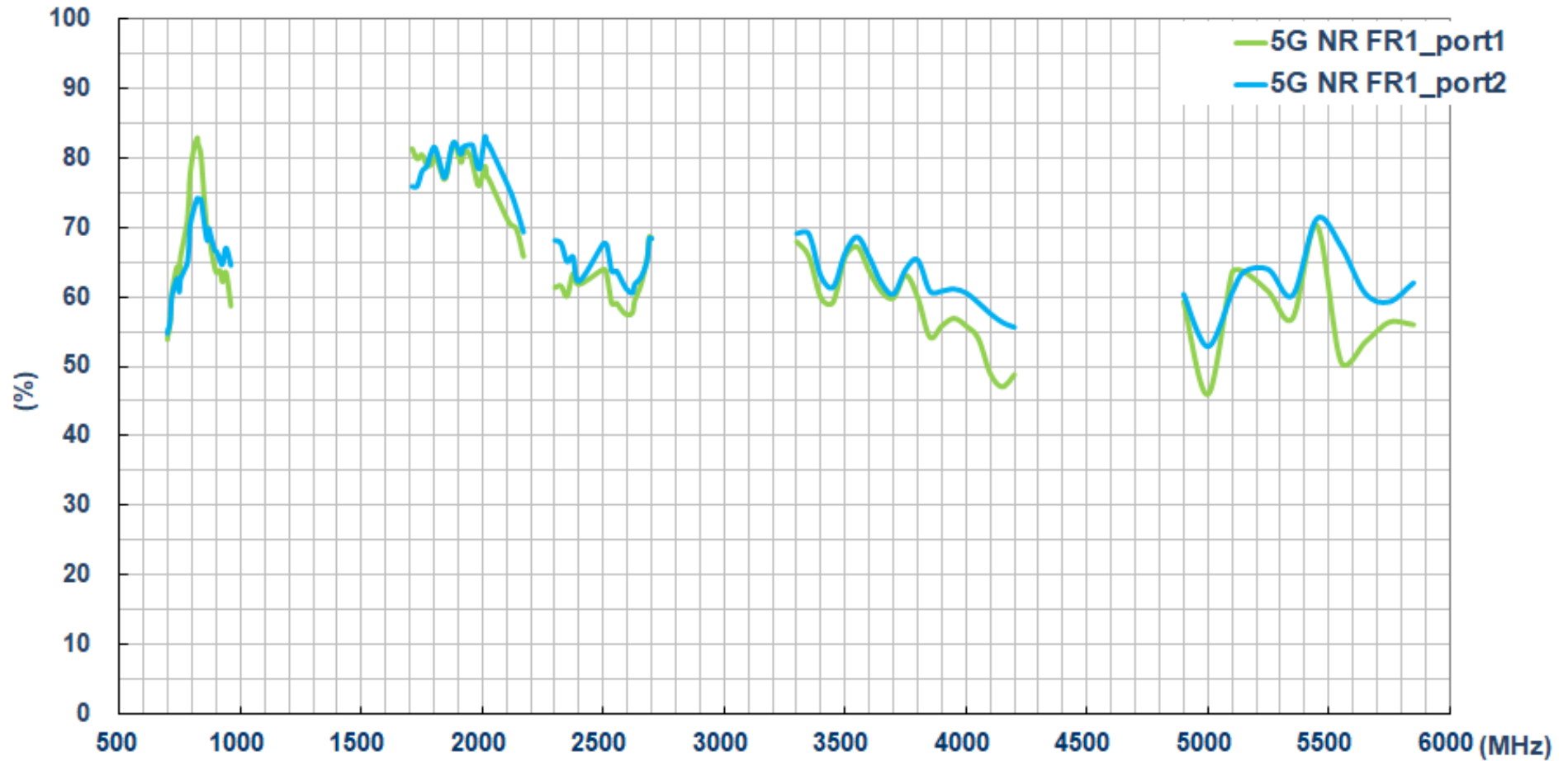

# Peak Gain\_5G NR FR1

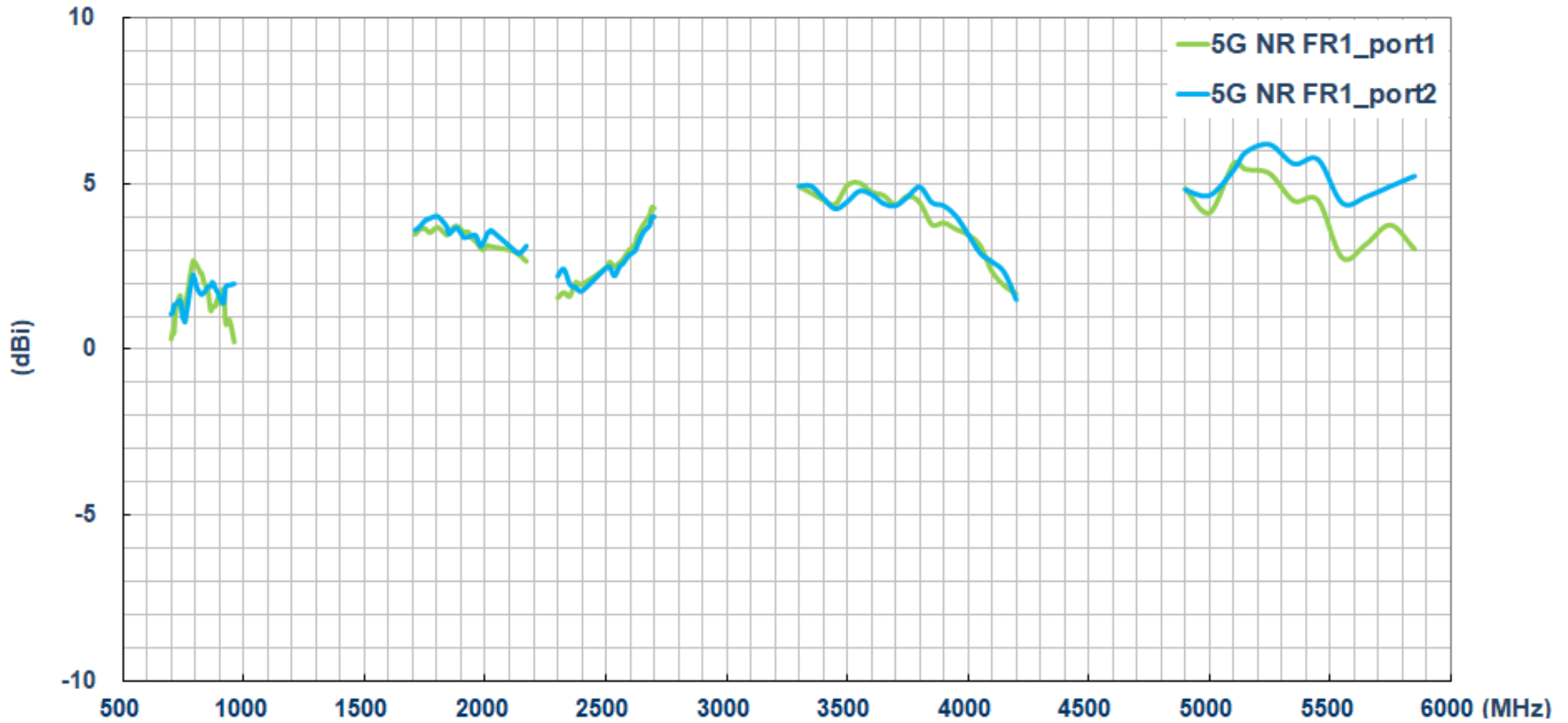

# Efficiency\_WiFi

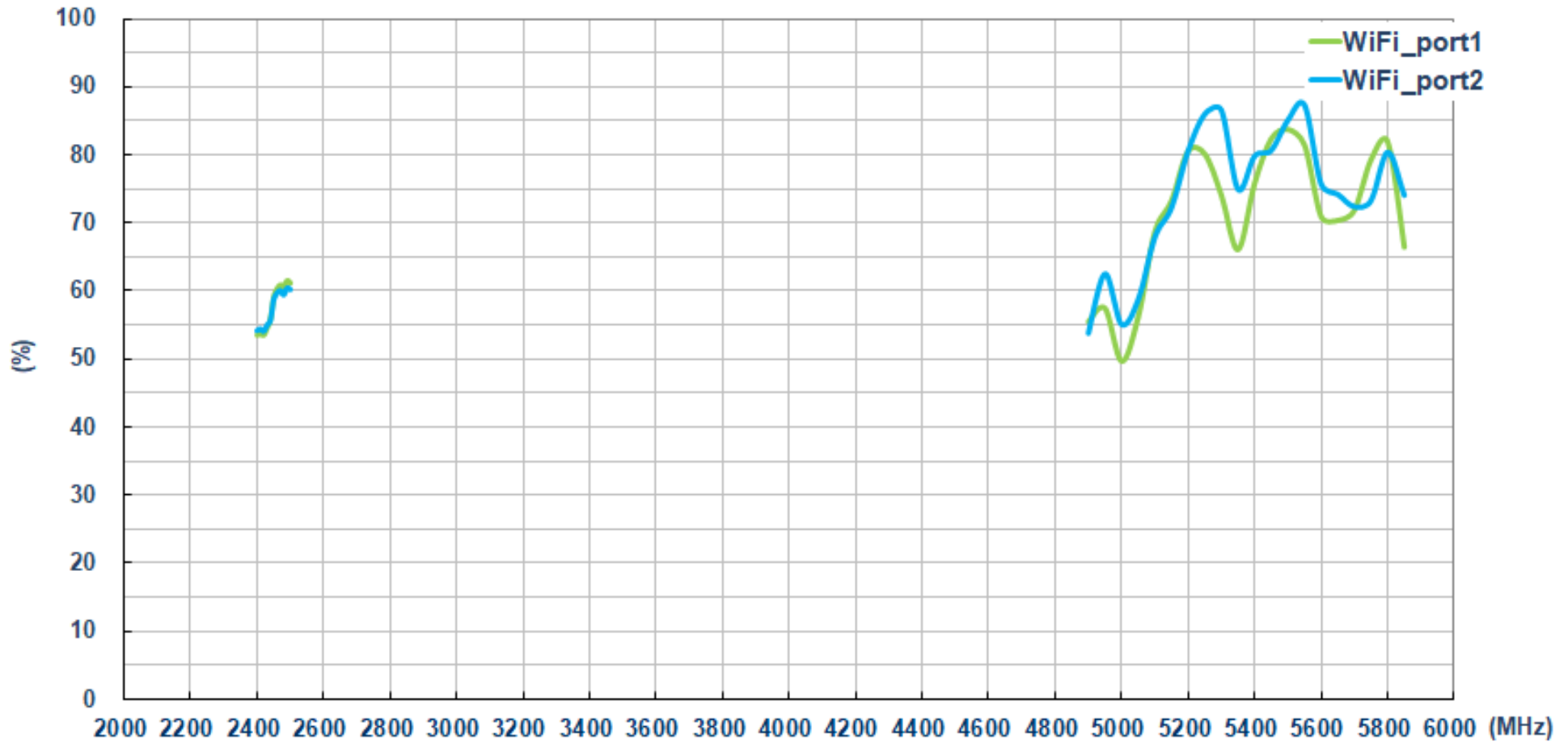

# Peak Gain\_WiFi

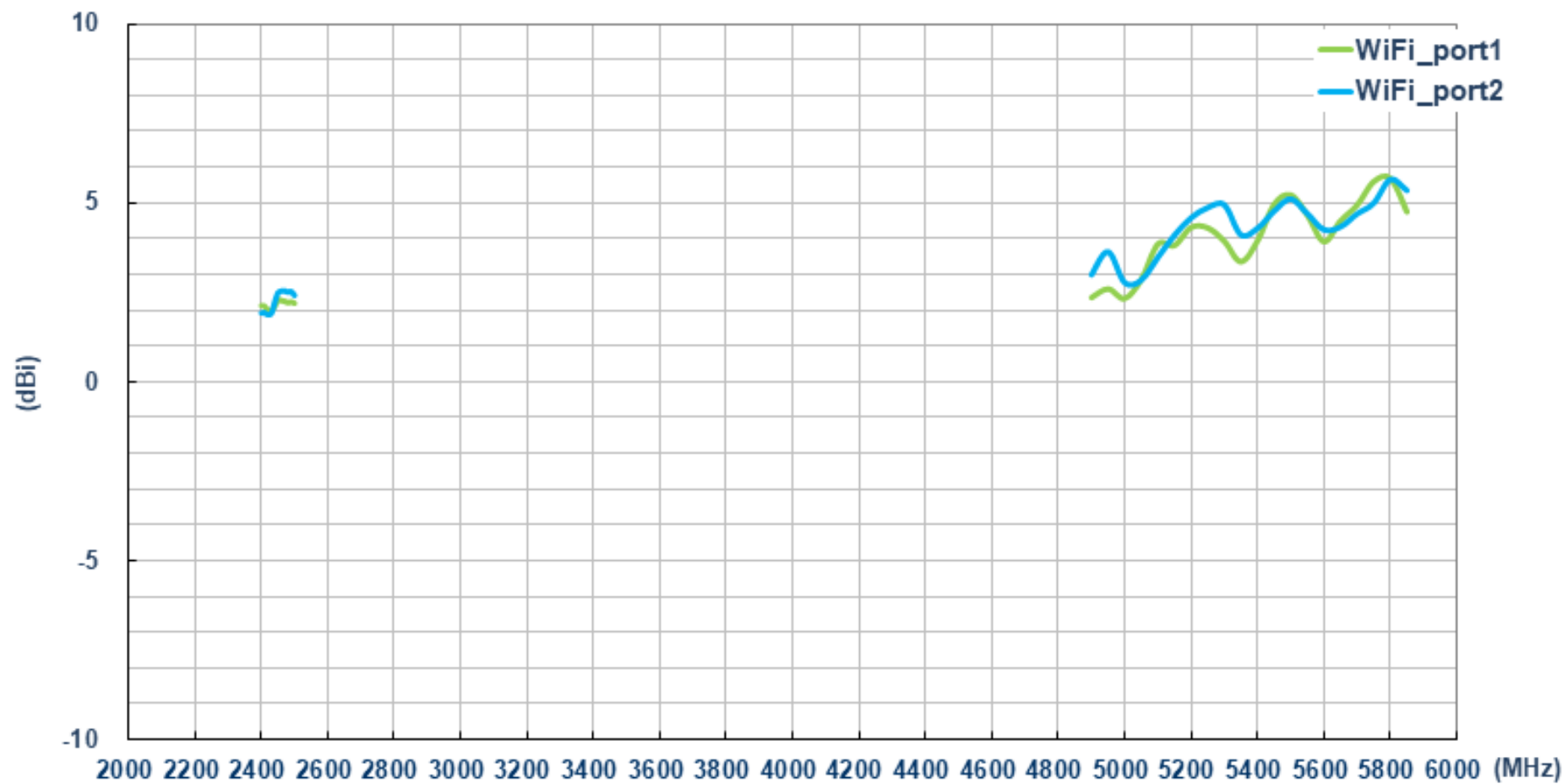



# Gain Table

	698~960	1710~2170	2300~2690	3300~4200	5150~5850
	<b>Efficiency</b>				
5G NR FR1_port1	66.75	77.62	61.80	58.68	58.52
5G NR FR1_port2	64.95	78.95	64.85	62.48	63.53
	<b>Peak gain</b>				
5G NR FR1_port1	2.68	3.73	4.29	5.02	5.43
5G NR FR1_port2	2.24	4.00	4.00	4.93	6.18

  

	WiFi 2.4G 2400~2500	WiFi 5G 4900~5850
	<b>Efficiency</b>	
WiFi_port1	57.72	75.89
WiFi_port2	57.46	78.89
	<b>Average gain</b>	
WiFi_port1	2.28	5.68
WiFi_port2	2.55	5.66

# 2D Radiation Pattern Results\_5G\_port1

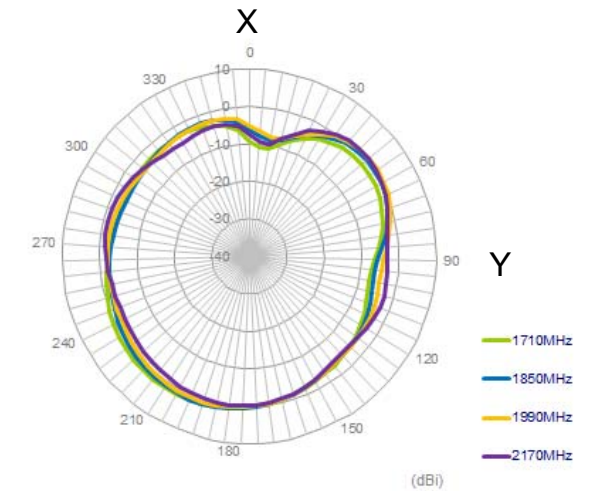
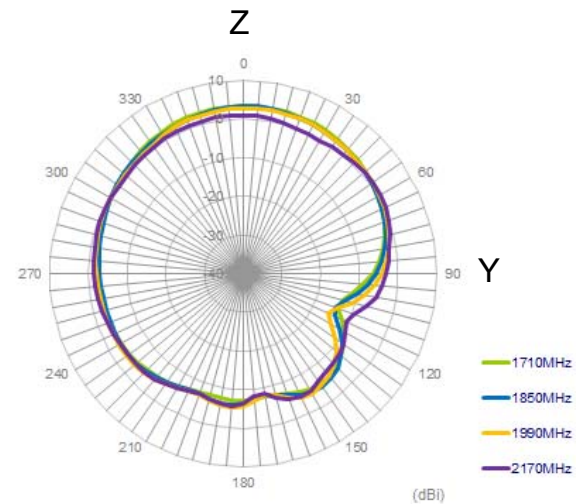
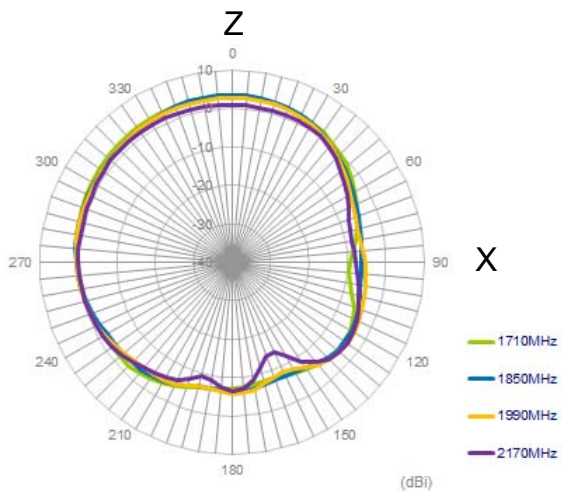
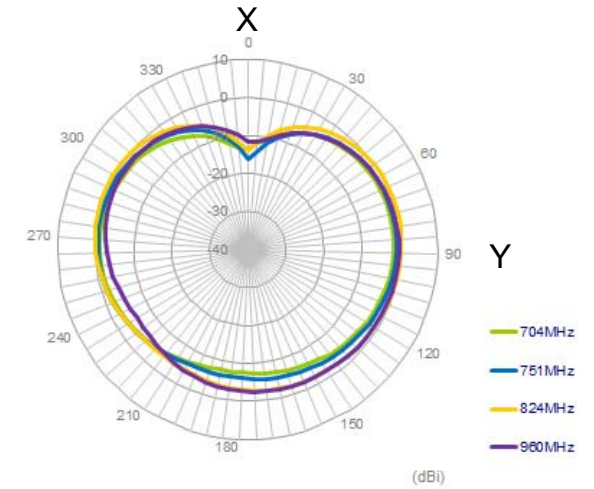
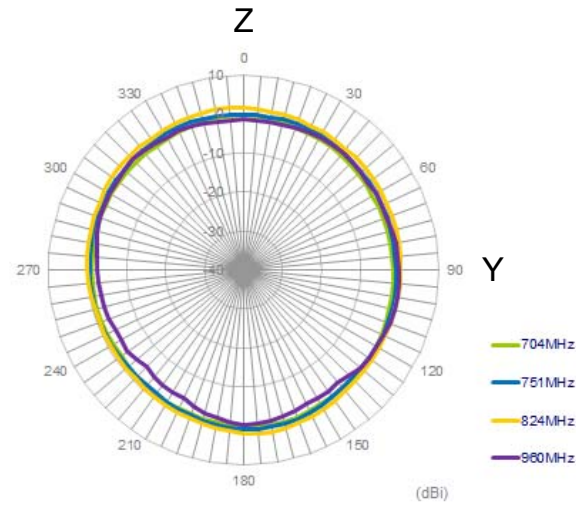
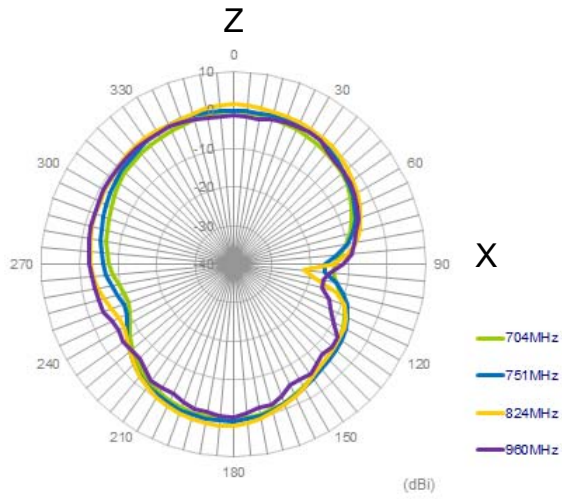

# 2D Radiation Pattern Results\_5G\_port1

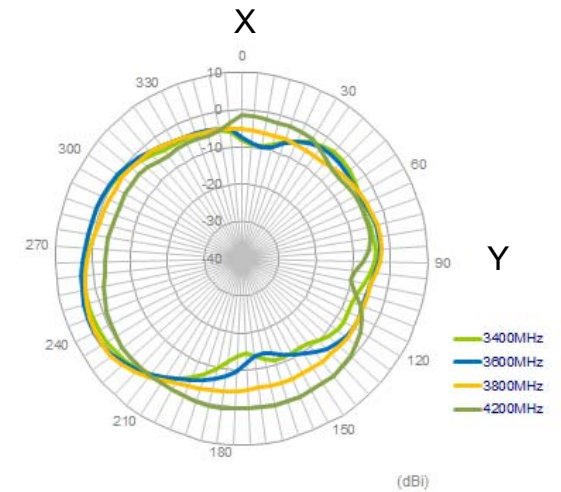
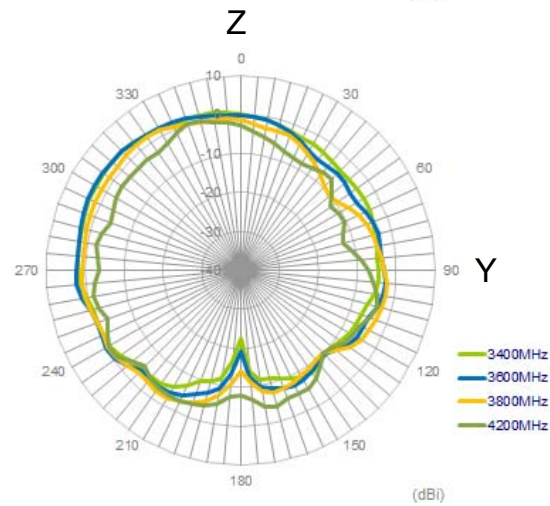
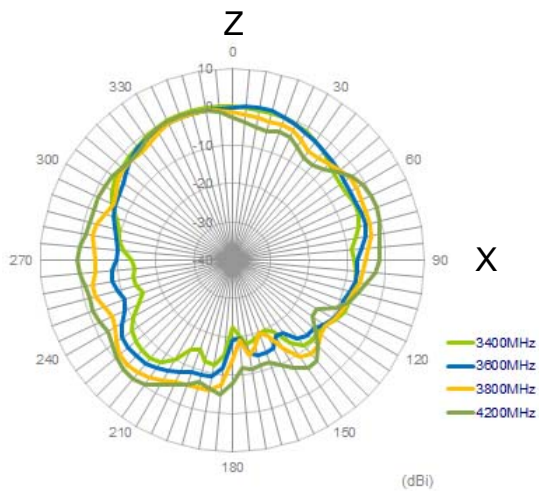
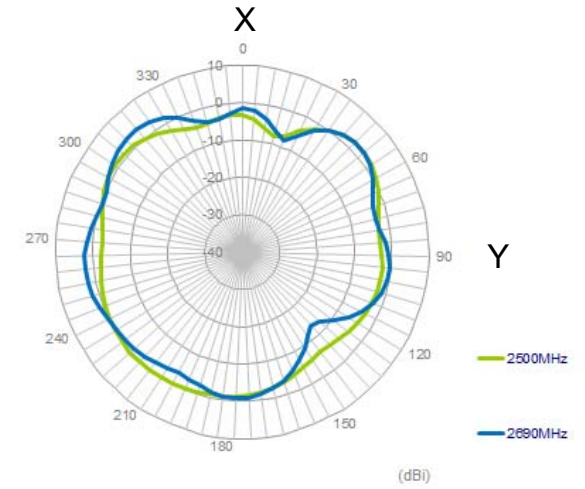
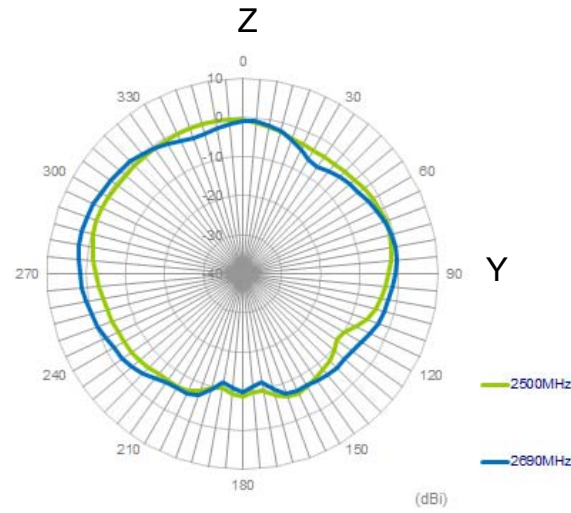
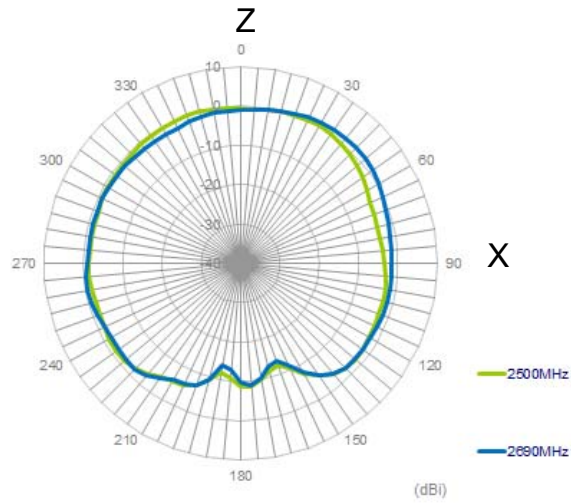

# 2D Radiation Pattern Results\_5G\_port1

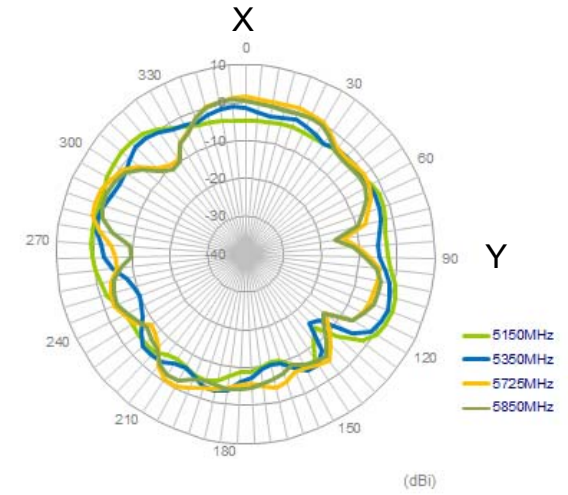
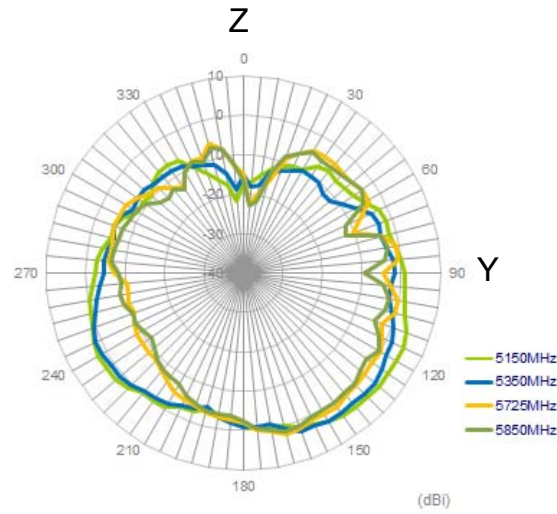
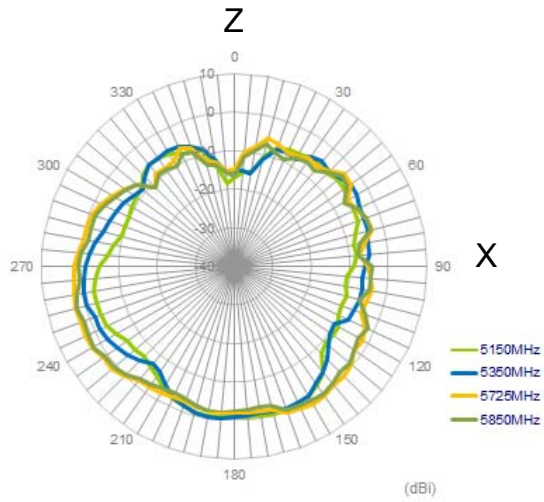



# 2D Radiation Pattern Results\_5G\_port2

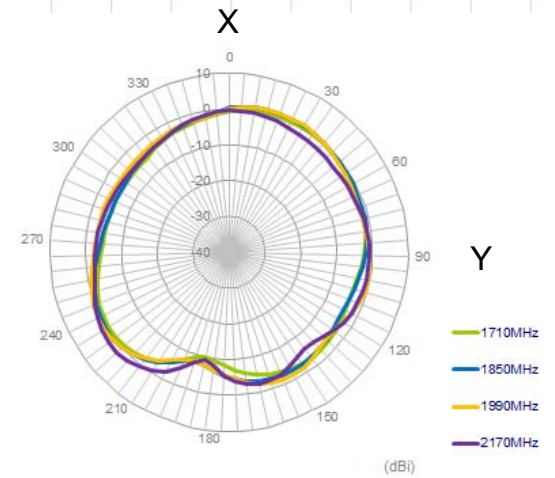
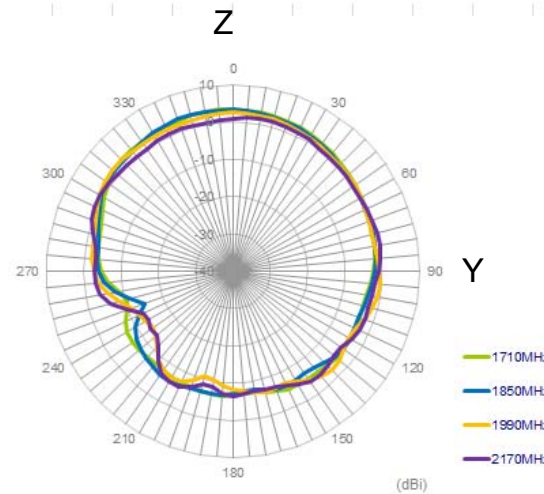
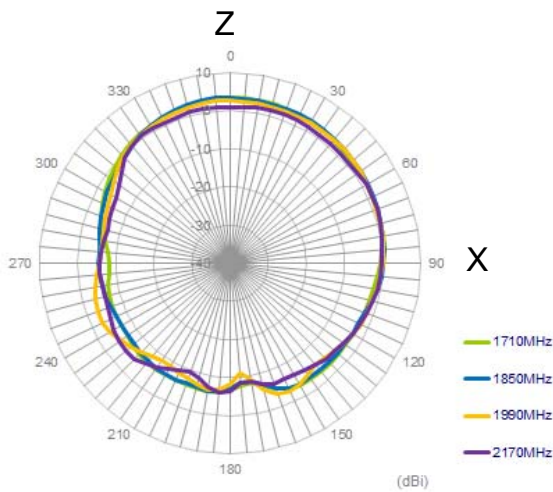
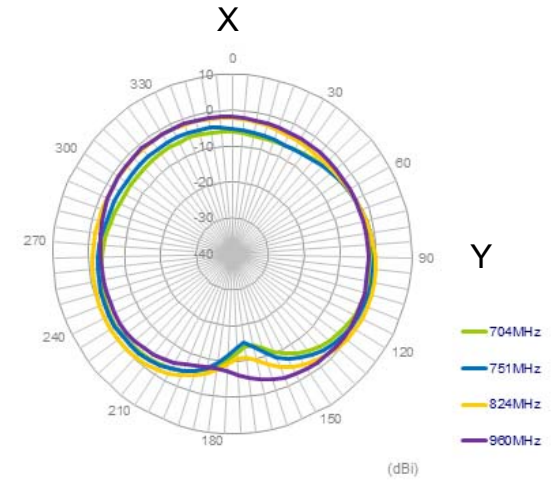
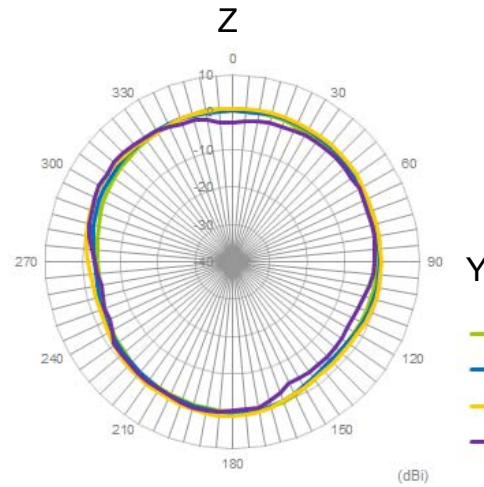
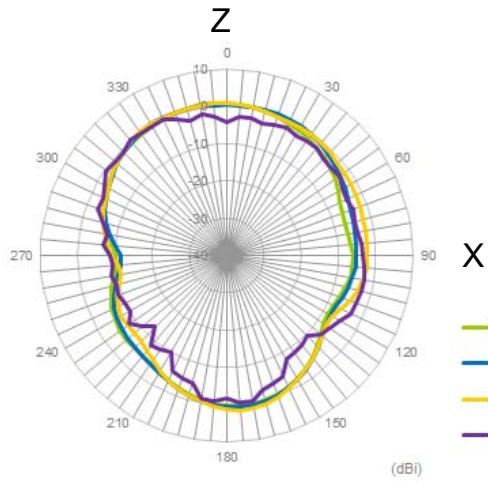

# 2D Radiation Pattern Results\_5G\_port2

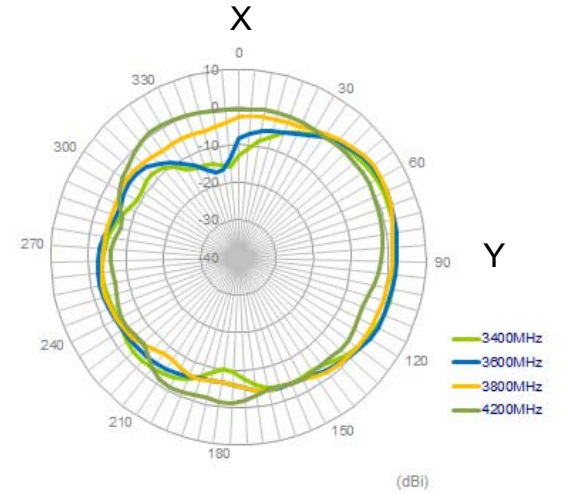
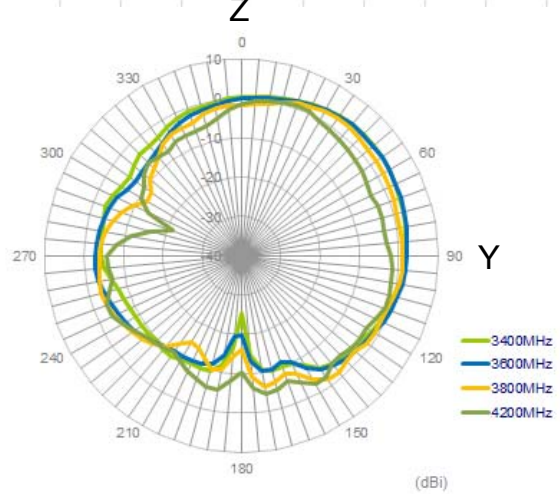
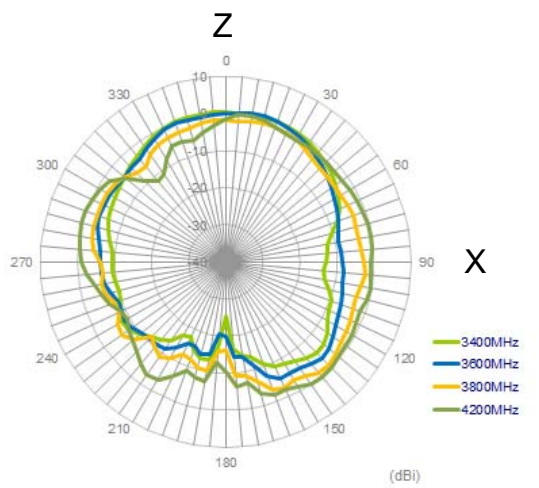
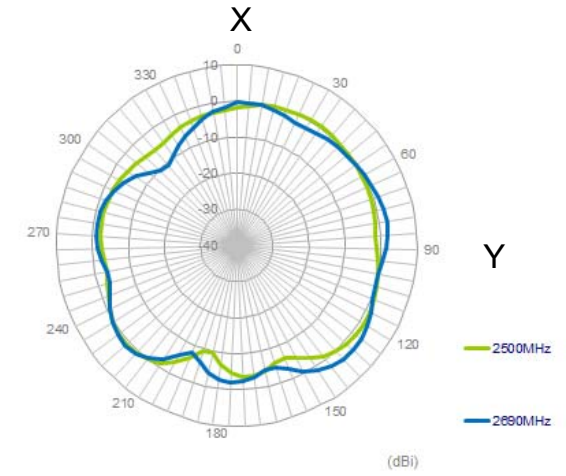
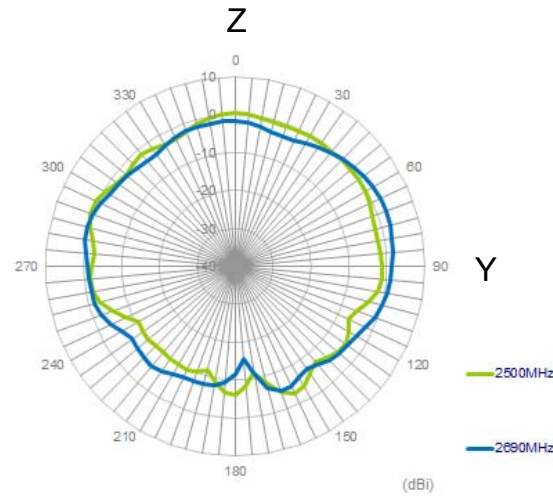
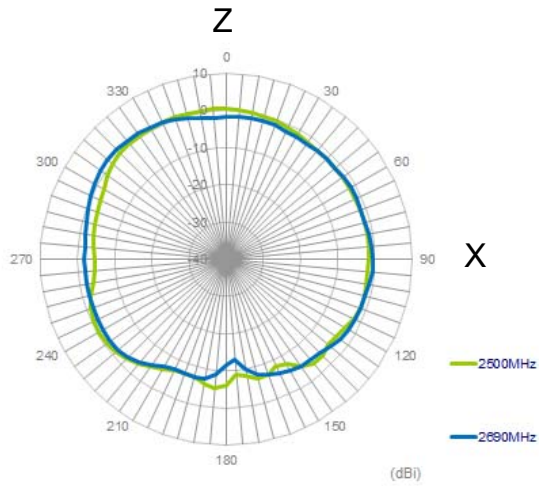

# 2D Radiation Pattern Results\_5G\_port2

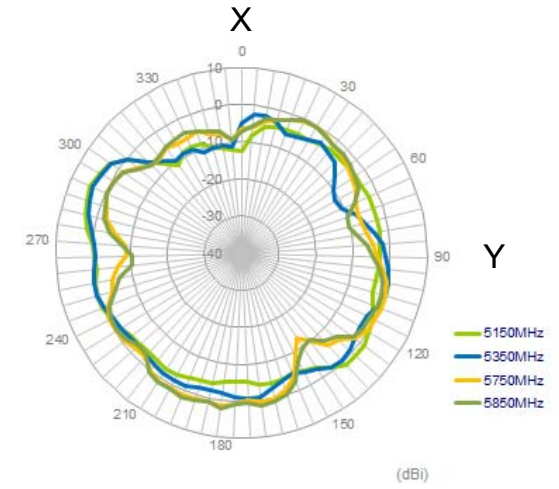
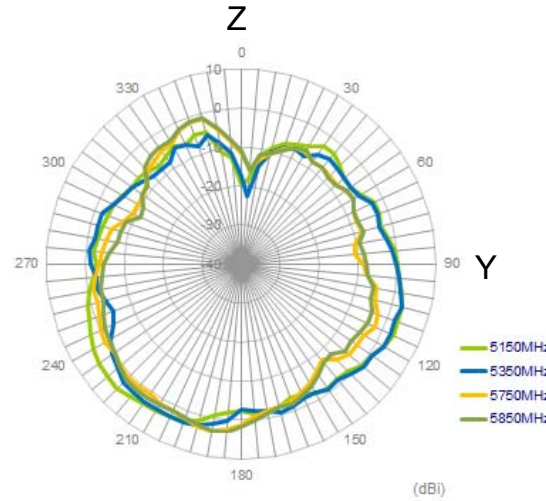
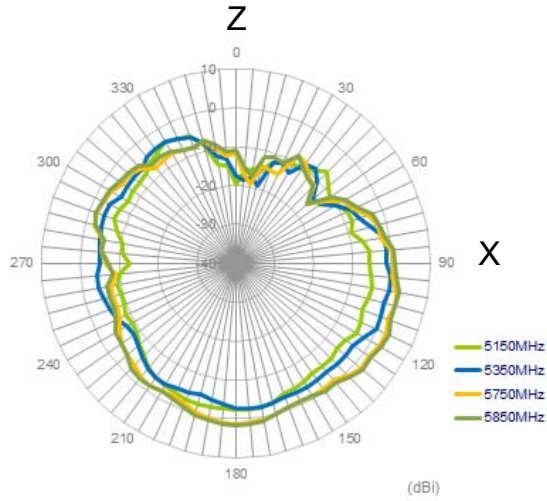



# 2D Radiation Pattern Results\_WiFi\_port1

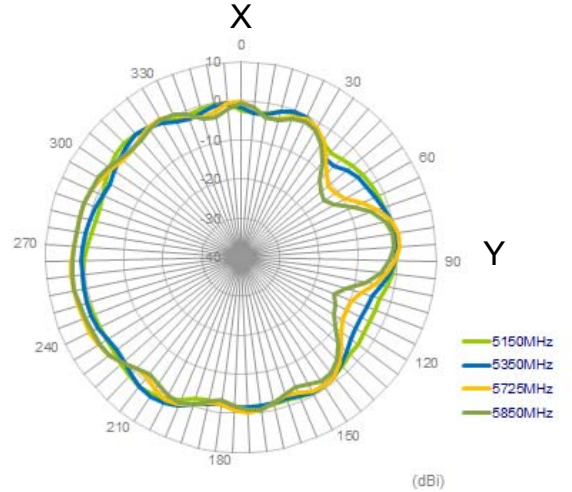
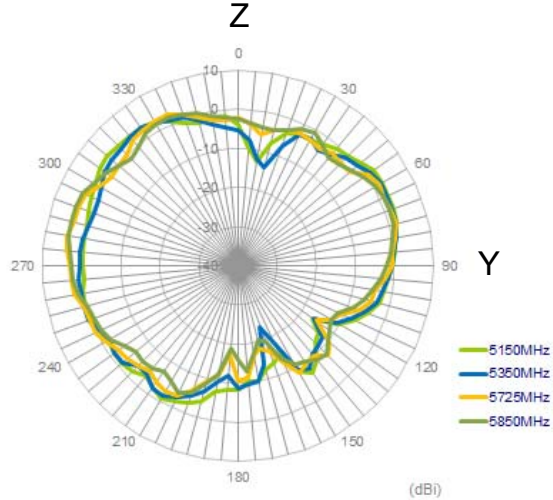
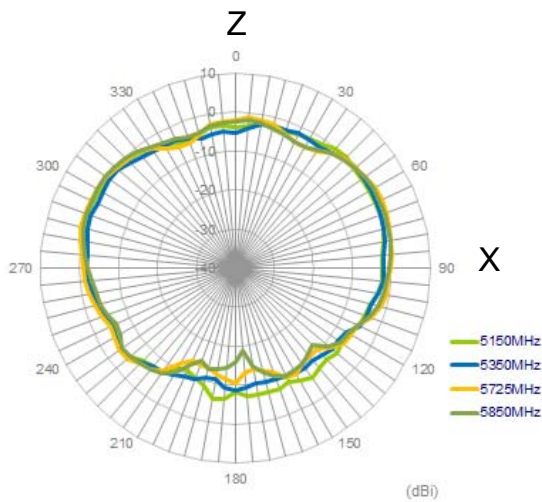
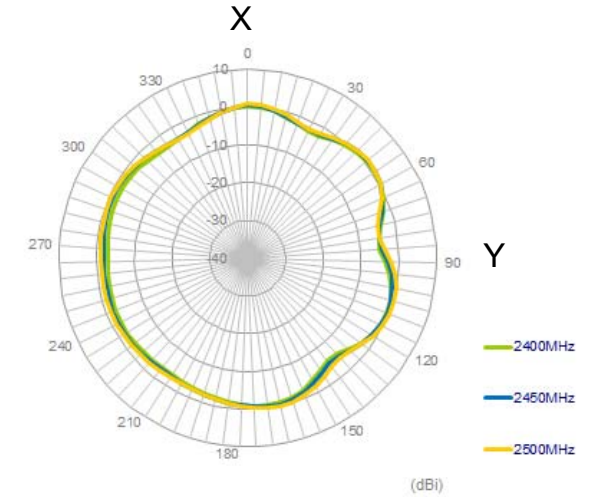
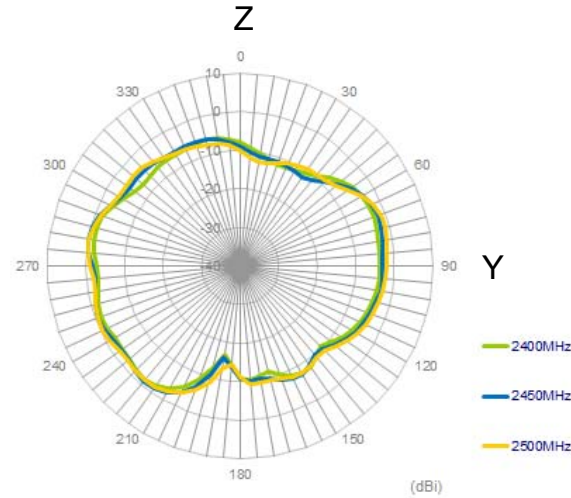
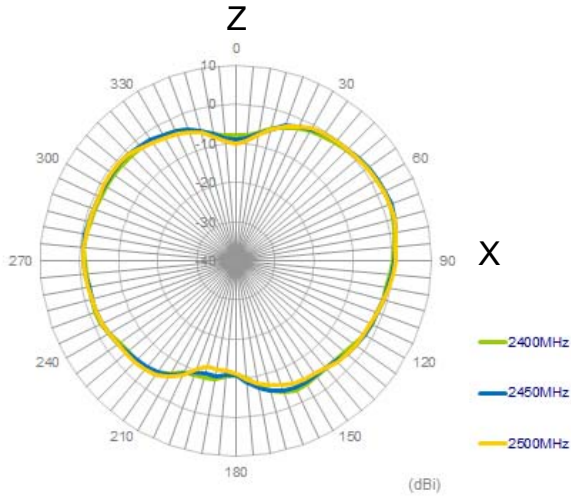



# 2D Radiation Pattern Results\_WiFi\_port2

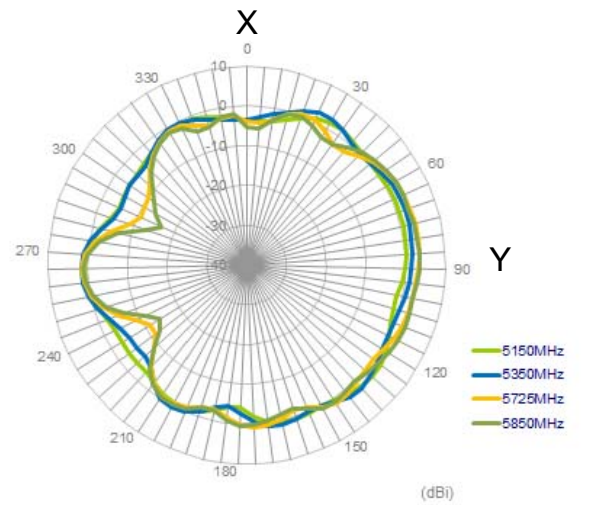
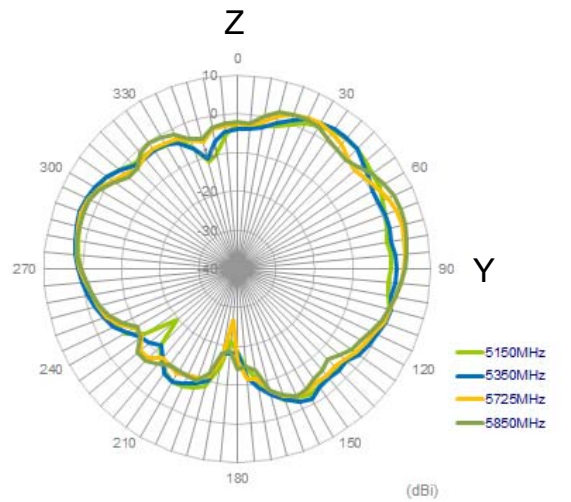
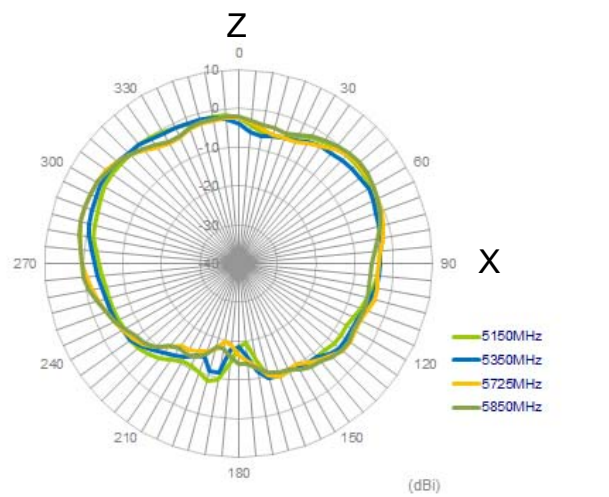
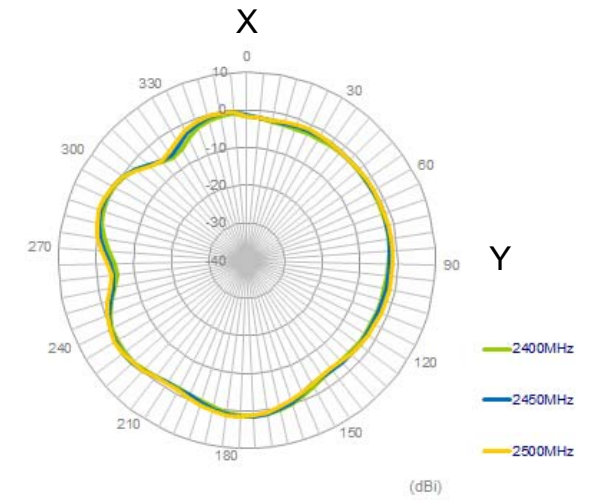
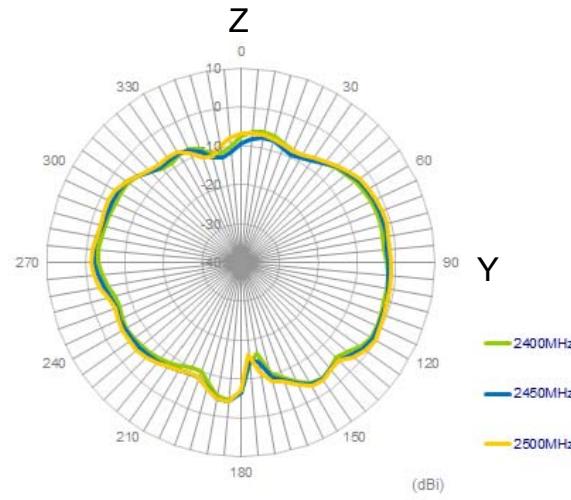
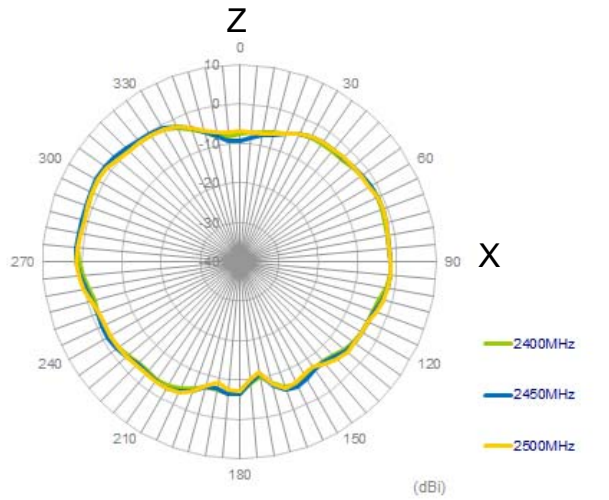

## Contact With RS

China Mainland:Rushun Technology Co., Ltd.

Dongguan Factory

Address: Humen Town, Dongguan City, GuangDong Province, 523932 China

Email: [King@rsantenna.com](mailto:King@rsantenna.com)

[Tel:+86](tel:+8613268639768) 13268639768

Taiwan: DingYang Technology Co., Ltd.

Taiwan Factory

Address:2F.-1, No. 18, Daren 2nd St., Zhongli Dist., Taoyuan City 320, Taiwan (R.O.C.)

Email: [terry@rsantenna.com](mailto:terry@rsantenna.com)

[Tel:+886](tel:+886978811326) 978-811-326